

**4,500 lbs**  
**CBD20**  
**24V Electric Pallet Truck**

**HELI**  
LIFTING THE FUTURE

Top 10 Forklift  
Manufacturer In The World



**CBD20**  
Electric Pallet Truck

**4,500 lbs**

Combination hour meter & battery discharge indicator

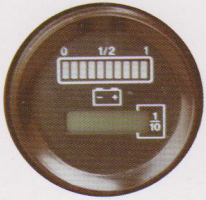

#### OPERATION/CONTROLS

- Ergonomic Handle
- Braking activation at top and bottom of handle working range
- Automatic braking on throttle release
- Low effort steering



CBD20-100

#### FORKS/CHASSIS

- 48" long x 27" wide O.D. forks
- Dual polyurethane load wheels

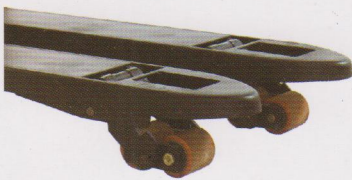

#### ELECTRICAL SYSTEM

- 24 Volt System w/built-in charger and 70 AHC battery pack
- State of the art Curtis AC traction controller provides seamless control
- Electric power steering system for ease of operation and lower power consumption(ON CBD20-150)

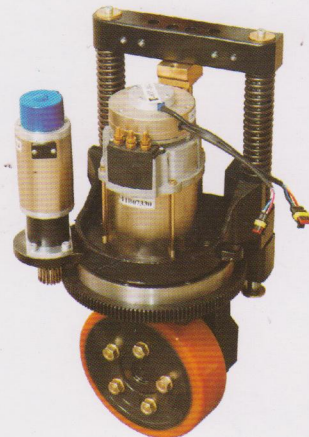
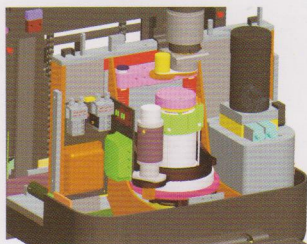

Manufacturer's Data and Design Characteristics				
Characteristics				
1	Model		CBD20	
2	Configuration Number		150	100
3	Steering Type		Electric	Manual
4	Operator Type		Walk-Behind	
5	Rated Capacity	Q(lbs)	4500	
6	Load Center	c(inch)	24	
7	Wheelbase	y(inch)	54.7	59
Wheels				
8	Tire Type		PU	
9	Drive Wheel	(inch)	$\phi 9.8 \times 3$	$\phi 10.5 \times 5$
10	Load Wheels	(inch)	$\phi 3 \times 3$	
11	Caster Wheels	(inch)	$\phi 4.5 \times 2.2$	$\phi 3.5 \times 1.9$
12	Wheels Number, Stabilizer/load (x=driving Wheels)		1x+1/4	1x+2/4
13	Tread/Rear	b11(inch)	14/15/16.3/19.7	
Dimensions				
14	Overall Height (handle Included)	h14(inch)	54.5	54.3
15	Overall Length	L1(inch)	69.9	73
16	Power Unit Length	L2(inch)	24	25.7
17	Power Unit Width	b1(inch)	28.3	30
18	Max. lifting height	h3(inch)	4.33	4.72
19	Fork lowered height	h13(inch)	3.35	
20	Fork thickness	s(inch)	2.17	
21	Fork width	e(inch)	7.28	
22	Fork length	L(inch)	45/48	
23	Forks O.D.	b5(inch)	21.2/22/24/27	
24	Outside turning radius,platform up/down	Wa(inch)	62	65.6
25	Right angle stacking width for pallet 42×48", platform up/down	Ast(inch)	91.5	94.5
Performances				
26	Travel Speed,With/Without load	mile/h	2.5/2.5	3.13/3.13
27	Lifting Speed,With/Without load	ft/min	11.0/11.8	
28	Lowering Speed,With/Without load	ft/min	11.2/11.6	
29	Gradeability,With/Without load	%	5/7	
30	Service Brake		Electromagnetic Braking	
Motor & Controller				
31	Drive Motor Power	kW	AC 1.5	DC 0.93
32	Lift Motor Power	kW	DC 2	
33	Battery Voltage/ Capacity	V/ Ah	24/210	
Weight				
34	Battery Weight	lbs	420	
35	Total Weight (including Battery)	lbs	1350	



**CBD20**  
Electric Pallet Truck

**4,500 lbs**

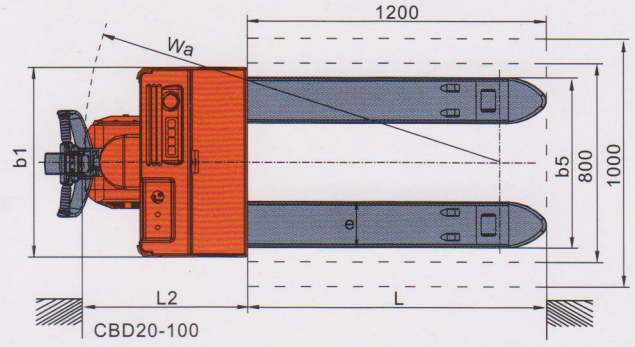
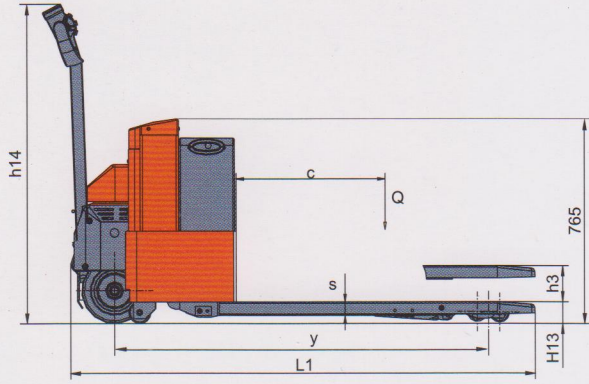

CBD20-100

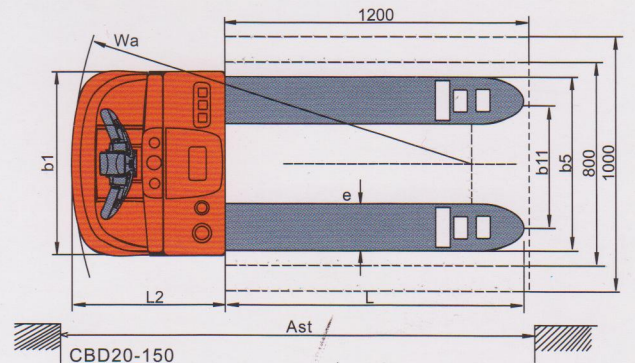
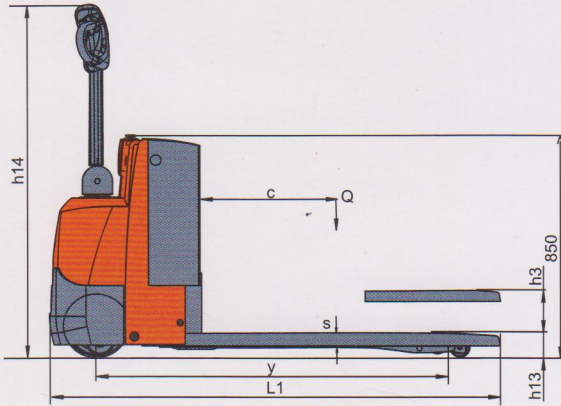

CBD20-150