



HELI

ENGINE POWERED **4-5t**

h2000
SERIES

CPCD40/45/50

CPQD40/45/50





Digital Instrument

- Clear and easy to read
- Instantaneous reading when switched on
- Ergonomical layout



Wide View Mast

- H2000 series forklift trucks are fitted with wide masts that give the operator greater visibility to the front

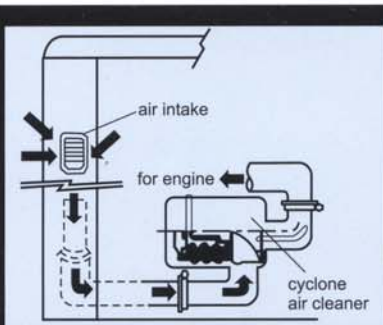

The large Intake Area of Air Intake System

- The snorkel air intake is situated on one of the pillars for the overhead guard, which is far from the dust being created by the wheels. It breathes in the clean air and reduces the noise.





The sound-absorbed materials

- Heat-insulation/vibration absorbing
- Lowest noise
- Rubber sealing packing at the gap between engine hood and truck body.



Superior Steering Axle

- Fully power assisted steering as standard which is compact and easy to maintain

HELI

FORKLIFT TRUCK

STANDARD DISTRIBUTION

Wide view mast
 Class-III carriage
 Loading bracket
 Standard fork
 Deluxe rubber floor mat
 Dipstick for tor-con oi
 J-lug long lift tire
 Overhead guard canvas
 Dipstick for hydraulic oil
 Overhead guard
 Overhead air intake
 Return hydraulic filter
 Standard seat
 Steering indicator
 Transmission fuel filter
 Cyclone air cleaner
 Lamp bracket
 Flow regulator on lift oil way
 Toggle type parking break lever
 Full hydraulic power steering
 Overhead lamp
 Lifting & tilting control lever
 Hour metre
 Rear combination lamp
 Two-spool control valve
 Water temperature gauge
 Backward lamp
 Fuel gauge
 Electric horn
 Anti-lock valve for tilting
 Air cleaner indicator
 Tilt adjustable steering column
 Rear view mirror
 Preheating indication system
 Neutral position safety switch
 Engine oil pressure indicator
 Charge indicator
 Engine auto glow system
 Back-up alarm
 Drawbar pin
 Ignition key engine stop
 Handle
 Tools
 Fuse broken circuit indication

OPTIONS AND MISCELLANEOUS

Dual drive wheel with fender
 Solid pneumatic tire
 Decreases black smoke fire proof silencer
 Enclosed cab
 Catalytic muffler
 Heater
 Overhead exhaust system
 Dual air cleaner
 Fire extinguisher
 Suspension seat
 Boot for fill cylinder and steering cylinder
 Dual fuel system (lpg/gasoline)
 Rear working light
 Custom color paint
 Steel mesh for protection
 Turning warning light
 Enterable container overhead guard

OPTIONAL ATTACHMENT

Enterable container wide view double mask with full free length
 Enterable container wide view triple mask with full free length
 Wide view full free 2-stage heighten mast
 Wide view double mask with full free length
 Wide view triplex mask with full free length
 Side shifter
 Widened fork holder
 Damp fork
 Lengthened fork
 Damp container
 Turning flat clip
 Sleeve on fork
 Load hawk
 Paper clip
 Multi function barrel clip
 Boom

Specification of Optional High Power Engine

Internal Combustion Engine Model	R4105	TB42A4GR1	S6S-31TEL	GM4.3L	S6S-Y3T31TFL
Model	weichai	NISSAN	MITSUBISHI	GM	MITSUBISHI
Kw(ps)/r.p.m	59/2300	66/2300	64.7/2300	61/2300	64/2300
Rate torque Nm/rpm	280/1600-1800	310/1800	284/1600	280/1400	293/1700
InternalCombustion Engine Number of Cylinder	4	6	6	V6	6
InternalCombustion Engine displacement	4.156	4.169	4.996	4.294	4.996
Applicable truck model	CPCD40/45/50WF	CPQD40/45/50R	CPCD40/45/50Sa1/2	CPYD40/45/50-TY1	CPCD40/45/50Sa3/4

STANDARD SPECIFICATION

Manufacturer
Model
Load Capacity
Load Center
Tire Type
Lifting Speeds (With load/Without load)
Lowering Speeds (With load/Without load)
Free lift
Max.Driving Speeds (With load/Without load)
Outside turning radius
Max.Gradeability (With load/Without load)
Max.Towing (With load/Without load)
Overall height (overhead guard)
Overall Lowered Height
Overall Raised Height
Goods fork (L×W×T)
Tire (Front)
Tire (Rear)
Min. under-clearance (bottom of mast)
Weight distribution of axle with load(front)
Weight distribution of axle without load(front)
Battery Voltage / Capacity
Service Brake
Parking Brake
Internal Combustion Engine Fuel Tank Capacity
Transmission Number of Speed
Total Weight

ANHUI HELI CO., LTD.

		CPCD40	CPCD45	CPCD50	CPYD40 CPQD40 CPQYD40	CPYD45 CPQD45 CPQYD45	CPYD50 CPQD50 CPQYD50	
	kg	4000	4500	5000	4000	4500	5000	
	mm	500						
		Air-tyre						
	mm/s	450/455	450/455	430/435	450/455	450/455	430/435	
d)	mm/s	≤595	≤595	≤595	≤595	≤595	≤595	
	mm	150	150	150	150	150	150	
oad)	km/h	24	24	24	24	24	24	
	mm	2720	2740	2800	2720	2740	2800	
)	%	19/20	16/18	15/17	19/20	16/18	15/17	
	N	21000/17800						
	mm	2270 (2230)						
	mm	2375						
	mm	4200						
	mm	1070*150*55						
		300-15-18PR						
		7.00-12-12PR						
	mm	158						
/rear)	kg	9010/1590	9750/1550	10500/1600	9010/1590	9750/1550	10500/1600	
ont/rear)	kg	2750/3850	2710/4090	2680/4420	2750/3850	2710/4090	2680/4420	
	V/Ah	2-12v/70Ah/20h			1-12v/100Ah/20h			
		Brake-foot step type						
		Mechanical-hand brake way						
apacity	L	90						
		2/1						
	kg	6600	6800	7100	6600	6800	7100	

STANDARD DIMENSIONS (Front Single Tire)

Model	CPCD40/CPQD40	CPCD45/CPQD45	CPCD50/CPQD50
	mm	mm	mm
A Overall height fork raised(with backrest)	4200	4200	4200
B Max. fork height	3000	3000	3000
C Overall height fork lowered(upright)	2375	2375	2375
D Backrest height(from upper face of forks)	1217	1217	1217
E Free lift	150	150	150
F Fork thickness	55	55	55
G Min. under-clearance(bottom of mast)	158	158	158
H Overall length(with forks)	4160	4180	4224
I Overall length(without forks)	3090	3110	3154
J Fork length	1070	1070	1070
K Fork overhang	570	570	570
L Wheel base	2000	2000	2000
M Rear overhang	520	540	584
N Coupler height	390	390	390
P Overall height(overhead guard)	2270 (2230)	2270 (2230)	2270 (2230)
Q Overall width	1480	1480	1480
R Lateral fork adjustment(Outside of fork)	300~1340	300~1340	300~1340
S Tread(front)	1180	1180	1180
T Tread(rear)	1190	1190	1190
U Fork width	150	150	150
V Inside turning	220	220	220
W Outside turning radius	2720	2740	2800
X Min. intersecting aisle	3345	3365	3410
Y Tilting angles(forward-backward)	6/12	6/12	6/12

HELI products and specifications are subject to improvement and change without notice.

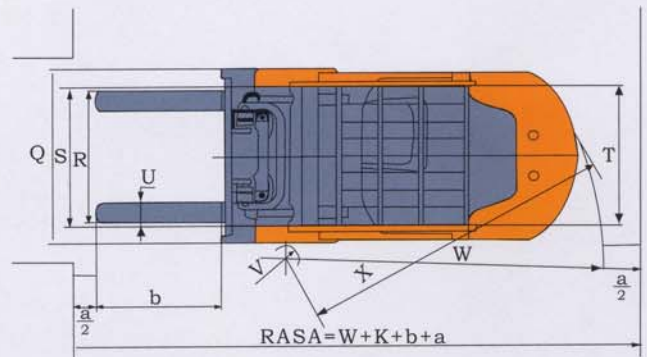
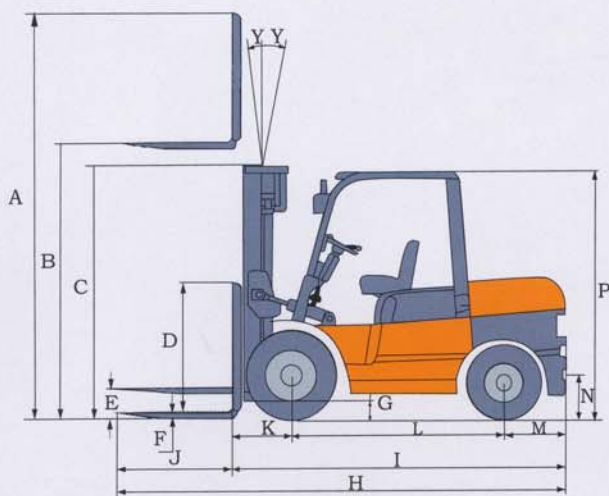

WIDE VIEW 2-STAGE MAST KM

Mast model	Max. fork height mm	Capacity at 500mm; Load center (kg)			Overall Mast Height at Lowered(mm)	Tilting Angle	Service Weight(kg)		
		CPCD50/CPQD50	CPCD45/CPQD45	CPCD40/CPQD40			CPCD50/CPQD50	CPCD45/CPQD45	CPCD40/CPQD40
KM260	2600	5000	4500	4000	2175	6°/12° 6°/6°	7050	6750	6550
KM300	3000	5000	4500	4000	2375	6°/12° 6°/6°	7100	6800	6600
KM330	3300	5000	4500	4000	2525	6°/12° 6°/6°	7130	6830	6630
KM350	3500	5000	4500	4000	2625	6°/12° 6°/6°	7160	6860	6660
KM370	3700	5000	4500	4000	2725	6°/12° 6°/6°	7180	6880	6680
KM375	3750	5000	4500	4000	2750	6°/12° 6°/6°	7190	6890	6690
KM400	4000	5000	4500	4000	2925	6°/12° 6°/6°	7260	6960	6760
KM425	4250	4850 *5000	4350 *4500	3850 *4000	3050	6°/12° 6°/6°	7300	7000	6800
KM450	4500	4600 *4800	4000 *4500	3600 *4000	3175	6°/12° 6°/6°	7310	7010	6810
KM475	4750	4300 *4800	3800 *4500	3400 *4000	3300	6°/12° 6°/6°	7360	7060	6860
KM500	5000	4000 *4600	3600 *4300	3100 *3700	3425	6°/12° 6°/6°	7400	7100	7000

WIDE VIEW FULL FREE 3-STAGE MAST KZSM

Mast model	Max. fork height mm	Capacity at 500mm; Load center (kg)			Overall Mast Height at Lowered(mm)	Free Lift Without Backrest (mm)	Tilting Angle	Service Weight(kg)		
		CPCD50/CPQD50	CPCD45/CPQD45	CPCD40/CPQD40				CPCD50/CPQD50	CPCD45/CPQD45	CPCD40/CPQD40
KZSM392	3920	4900	4400	3900	2230	1430	6°/6° 3°/6°	7700	7440	7240
KZSM435	4350	4700	4300	3800	2375	1575	6°/6° 3°/6°	7810	7550	7350
KZSM450	4500	4600	3800	3400	2426	1626	6°/6° 3°/6°	7840	7580	7380
KZSM470	4700	4600	3800	3400	2492	1692	6°/6° 3°/6°	7860	7600	7400
KZSM480	4800	4600 *4600	3800 *4200	3400 *3700	2525	1725	6°/6° 3°/6°	7890	7630	7430
KZSM500	5000	4400 *4500	3300 *4100	3300 *3600	2625	1825	6°/6° 3°/6°	7930	7670	7470
KZSM540	5400	3400 *4300	3000 *3900	3000 *3400	2750	1950	6°/6° 3°/6°	8010	7750	7550
KZSM600	6000	2500 *4000	2200 *3500	2200 *3200	2990	2190	6°/6° 3°/6°	8080	7820	7620

WIDE VIEW FULL FREE 2-STAGE MAST KZM

Mast model	Max. fork height mm	Capacity at 500mm; Load center (kg)			Overall Mast Height at Lowered(mm)	Free Lift Without Backrest (mm)	Tilting Angle	Service Weight(kg)		
		CPCD50/CPQD50	CPCD45/CPQD45	CPCD40/CPQD40				CPCD50/CPQD50	CPCD45/CPQD45	CPCD40/CPQD40
KZM261	2610	5000	4500	4000	2180	1380	6°/12° 6°/6°	7050	6750	6550
KZM300	3000	5000	4500	4000	2375	1575	6°/12° 6°/6°	7170	6870	6670
KZM330	3300	5000	4500	4000	2525	1725	6°/12° 6°/6°	7200	6900	6700
KZM350	3500	5000	4500	4000	2625	1825	6°/12° 6°/6°	7230	6930	6730
KZM375	3750	5000	4500	4000	2750	1950	6°/12° 6°/6°	7260	6960	6760
KZM400	4000	5000	4500	4000	2875	2075	6°/12° 6°/6°	7330	7030	6830

Dual wheel dimensions with*

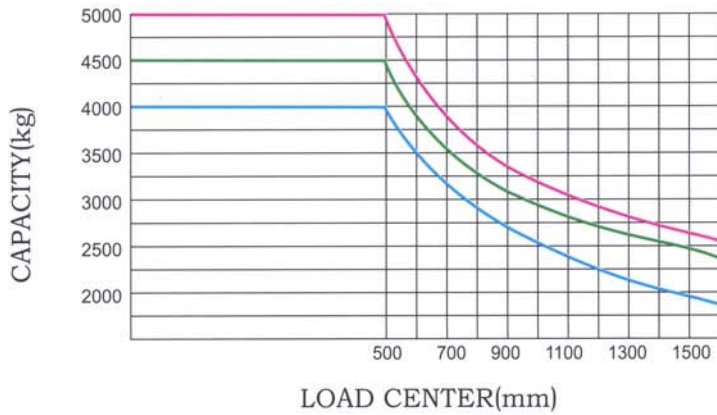

Note:

Capacities shown are computed with upright in vertical position. Load centers are determined for front face of forks. Capacities are based on a 1000 mm cube load configuration with the center of gravity at the true center of the cube, and standard forks. Truck capacities with upright in forward tilt position will be less. Long forks, and unusually wide or loads may also reduce capacity.

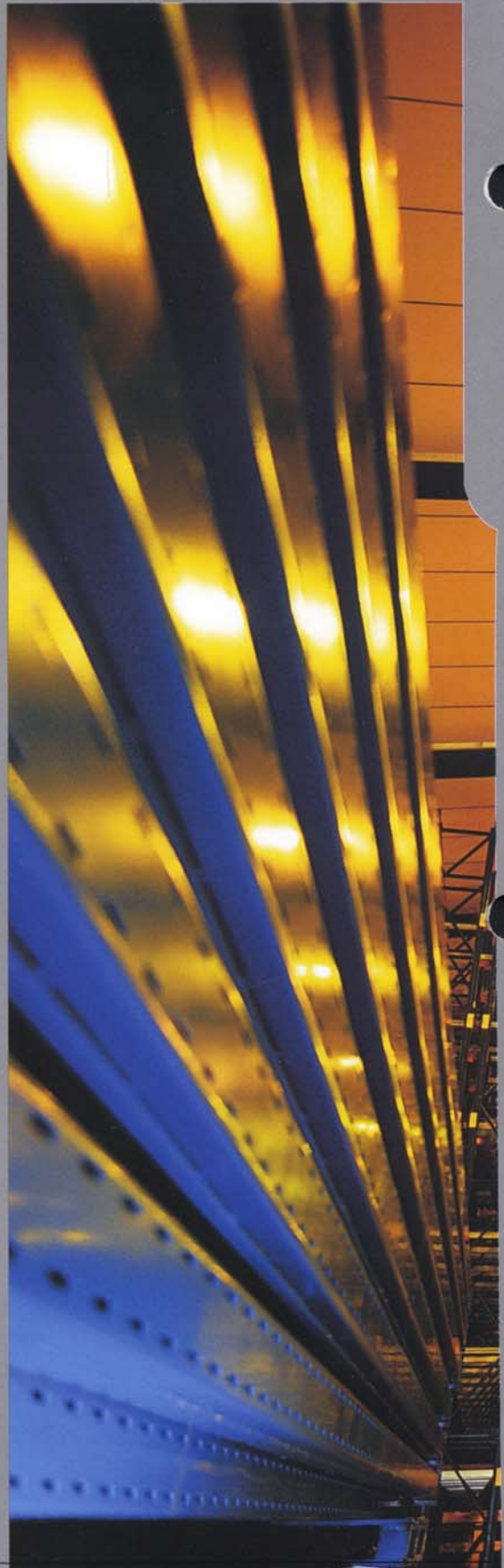

Frontier Forklifts

Sales • Service • Parts • Rentals



281-482-4500