

EPJ-45

Low cost electric pallet truck, ideal for crowded loading docks, work cells and congested aisles.

CAPACITY

- 4500 lb

BATTERY

- 24-volt industrial battery/battery pack
- 224Ah AGM maintenance-free battery pack
- Minimum battery weight: 480 lb
- Ah capacity (min/max): 180/255
- Compartment dimensions (open): 26.37" x 9.06"
- Connector: SB-175 Gray—A-11

SPEED

- ZAPI AC-0 Travel Controller

- **EMPTY:** 0 - 3.66 mph
- **LOADED:** 0 - 3.5 mph

WEIGHT

- 940 lb (chassis only)

TIRES / WHEELS

- **DRIVE:** 9" x 3" polyurethane
- **LOAD:** 3.3" x 4.5" polyurethane
- Press-on polyurethane drive tire

HYDRAULICS

- Hard chrome lift cylinder
- Pump unit including motor, gear pump, and solenoid are actuated using pressure compensated lowering valve

ELECTRICAL

- 24-volt
- ZAPI AC-0 travel control-inverter
- Monarch drive motor
- Automatic rise and fused circuit protection
- Low battery lift interrupt
- Hour meter / Battery discharge indicator combo

BRAKES

- Electromagnetic brake
- ZF GK10 transmission
- Brake is applied when control arm is in the vertical or horizontal position
- Regenerative neutral braking

OPERATION / CONTROLS

- Ergonomic operator handle
- Wrap-around guard
- Reversing switch



- Thumb control
- Horn
- Gas-assisted spring handle
- Creep speed function while steer handle is at 5° back-tilt from vertical
- Fingertip control

TRANSMISSION

- Vertically mounted drive motor
- Oil-bathed ZF GK10 hypoid bevel gear drivetrain
- State-of-the-art optimized gear technology provides minimal envelope circle, zero maintenance, and low noise level

BEARINGS

- **DRIVE WHEEL:** Tapered roller bearings sealed in oil bath
- **LOAD WHEELS:** Sealed ball bearings
- **FORK LINKAGE:** Self-lubricated heat-treated bushing

ACCESSIBILITY

- Removal of one piece power head cover exposes major components for inspection and maintenance
- Drive tire can be removed with one nut

STANDARD EQUIPMENT

- Steel wrap-around bumper

OPTIONAL EQUIPMENT

- Fork lengths and fork widths
- Load backrest
- Stability casters
- (4)6V 180Ah maintenance-free battery pack with built-in 110VAC charger
- (1) 24V 255Ah industrial battery

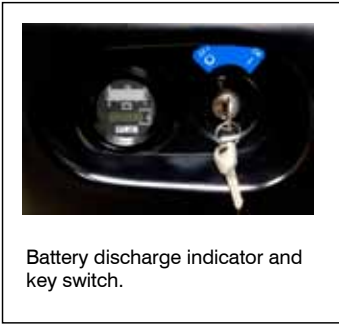

Battery discharge indicator and key switch.

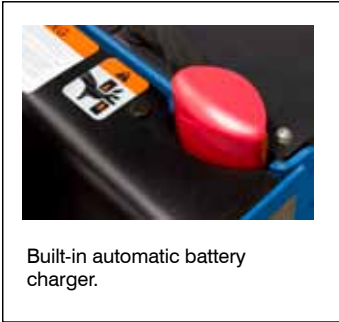

Built-in automatic battery charger.



Ergonomic operator's handle

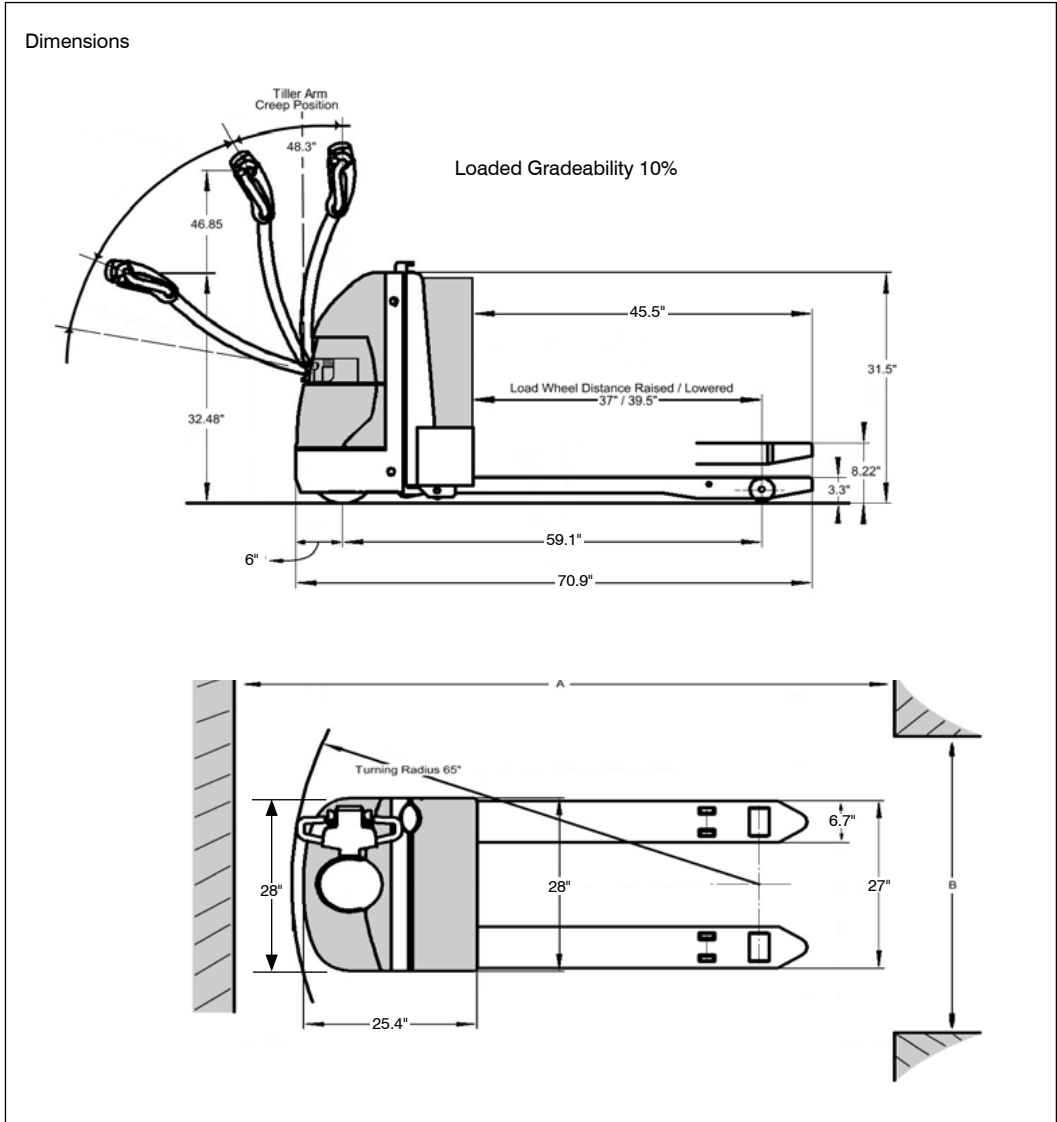

Gradeability

Without Load	10%
With Load	6%

Travel - Variable

Empty	0 to 3.6 mph
Loaded	0 to 3.5 mph

Truck model	Forks	Actual Fork Width	Actual Fork Length	Turning Radius	Wheelbase	Overall Length	Inside Fork Width	³ Weight (lb)
		A	B	C	D	E	F	

Fork Dimension: 27" Wide

EPJ-45	27" x 36"	27"	33.5"	56"	50.1"	61.9"	13.4"	875
EPJ-45	27" x 42"	27"	38.5"	61"	54.6"	66.4"	13.4"	880
EPJ-45	27" x 48"	27"	45.5"	68"	59.1"	70.9"	13.4"	885
EPJ-45	27" x 60"	27"	57.5"	80"	73.7"	85.5"	13.4"	910

Fork Dimension: 21" Wide

EPJ-45	21" x 36"	21"	33.5"	56"	50.1"	61.9"	7.6"	875
EPJ-45	21" x 48"	21"	45.5"	68"	59.1"	70.9"	7.6"	880

Fork Dimension: 18" Wide

EPJ-45	18" x 36"	18"	33.5"	56"	50.1"	61.9"	4.6"	875
EPJ-45	18" x 48"	18"	45.5"	68"	64.9"	70.9"	4.6"	880

Dimensions listed above are based on 9.1" battery compartment

³ Estimated shipping weight with (2) battery



Corporate 85 Heart Lake Road South
Brampton, ON, Canada L6W 3K2
t 905.457.3900 f 905.457.2313

USA 6350 Burnt Poplar Road
Greensboro, NC 27409
www.BlueGiant.com

IT-EPJ-45-US-082514